



Stage Plot & Input List

Contacts:

Rob Harvey – Band Leader, 847.721.7287

Toby Ankebrant – Stage Manager/Monitor Engineer, 815.541.4777

Nick Walczak – Video Engineer/Lead Lighting Technician, 262.409.5293

Bella Cain Input List

Instrument/Mics	Channel
Kick	1
Snare	2
Hi Hat	3
Tom 1	4
Tom 2	5
Tom 3	6
Tom 4	7
Kick Trigger*	8
Snare Trigger*	9
Click	10
Bass	11
Keys	12
Jud Guitar	13
Fred Guitar	14
Russ Fiddle	15
Banjo	16
Acoustic	17
Steel Guitar	18
Jud Vocals	19
Amber Vocals	20
Russ Vocals	21
Fred Vocals	22
Patrick Vocals	23
Rob Vocals	24
*Electronic drums may not be used, depending on set length	Rob Harvey – Band Leader 847.721.7287
**Depending on sound engineer, four extra mics can be used for drums Kick/Snare/ 2 over heads	Toby Ankebrant – Monitor Engineer 815.541.4777

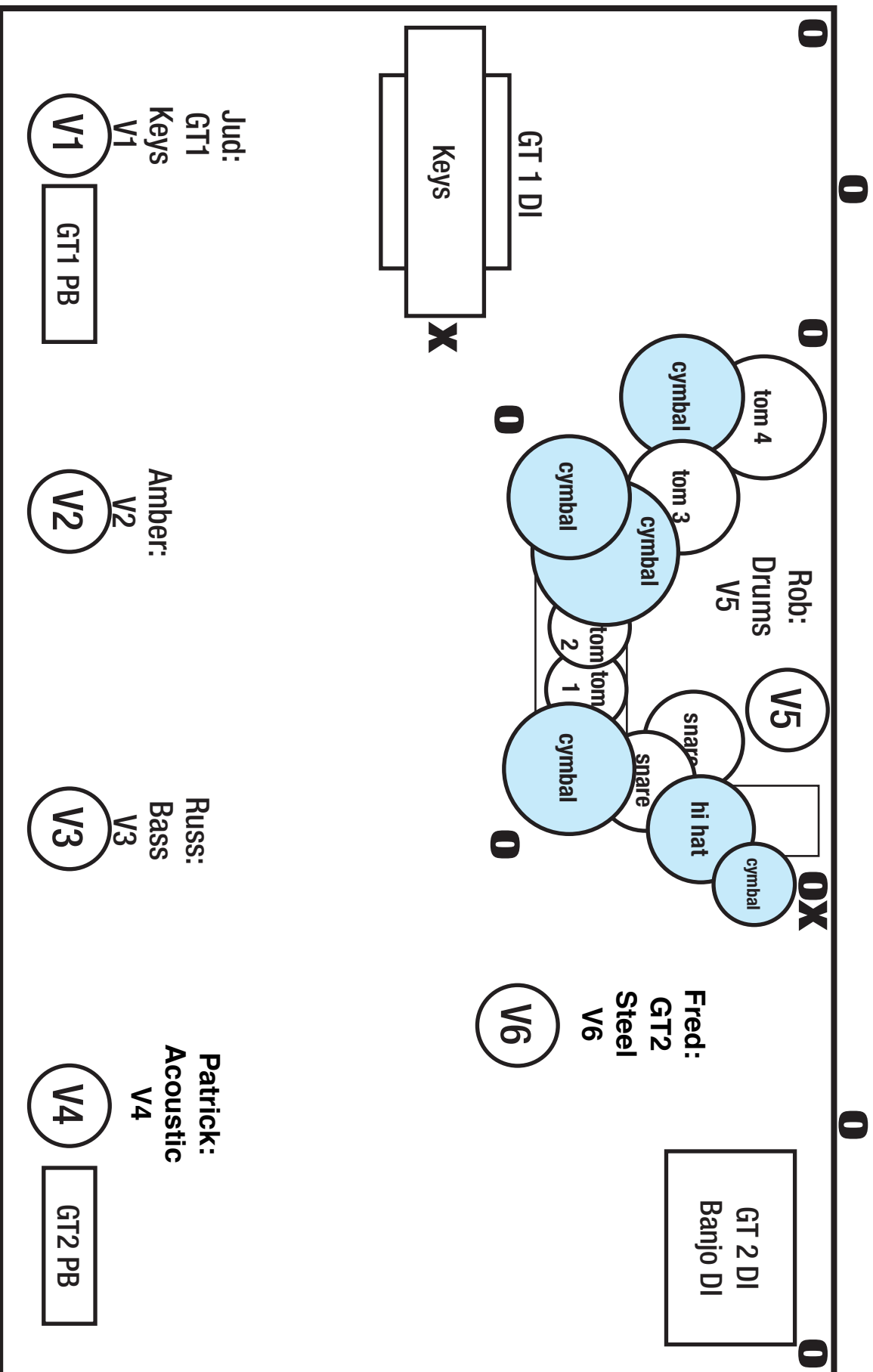

X
 Monitor board can be on either side of the stage. Also will need small area for tech work and instrument storage.

Bella Cain Stage Plot

Rob Harvey – Band Leader, 847.721.7287

Toby Ankebrant – Stage Manager/Monitor Engineer, 815.541.4777

Nick Walczak – Video Engineer/Lead Lighting Technician, 262.409.5293

**X – Power Drops for Band
 0 – Power Drops for Lights**

Lights require 7 separate 20 amp circuits

Band power can run on one 20 amp circuit